

SFP 2x1 CAGE Assembly

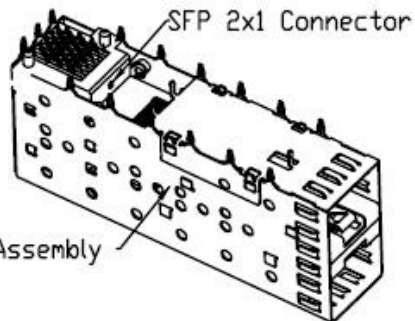

SFP 2x1 Connector

NOTE:  
 MECHANICAL:  
 CONNECTOR MATERIAL:  
 1.HOUSING: HIGH TEMPERATURE THERMOPLASTIC  
 GLASS FIELD: UL94V-0,  
 : STANDARD COLOR :BLACK,  
 2.CONTACT: PHOS-BRONZE THICKNESS=0.20mm.  
 3.DURABILITY: 100 CYCLES MIN.  
 ELECTRICAL:  
 DIFFERENTIAL IMPEDANCE: 100 Ohms.  
 TEMPERATURE:  
 OPERATION: -40°C~ +85°C  
 STORAGE: -40°C~ +85°C  
 RoHS COMPLIANT  
 PART NUMBER: SFP021-L

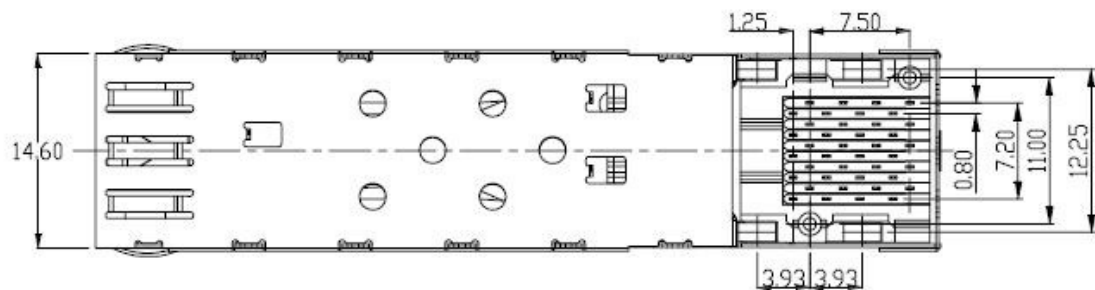
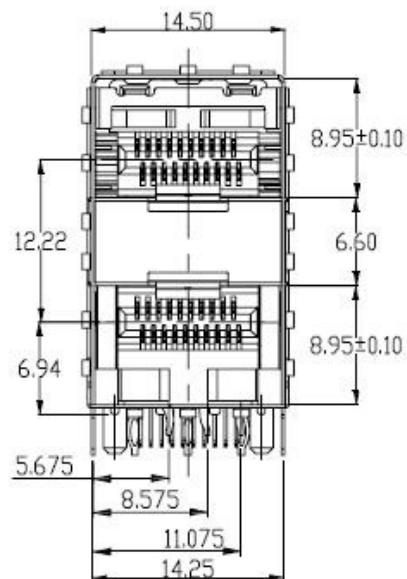
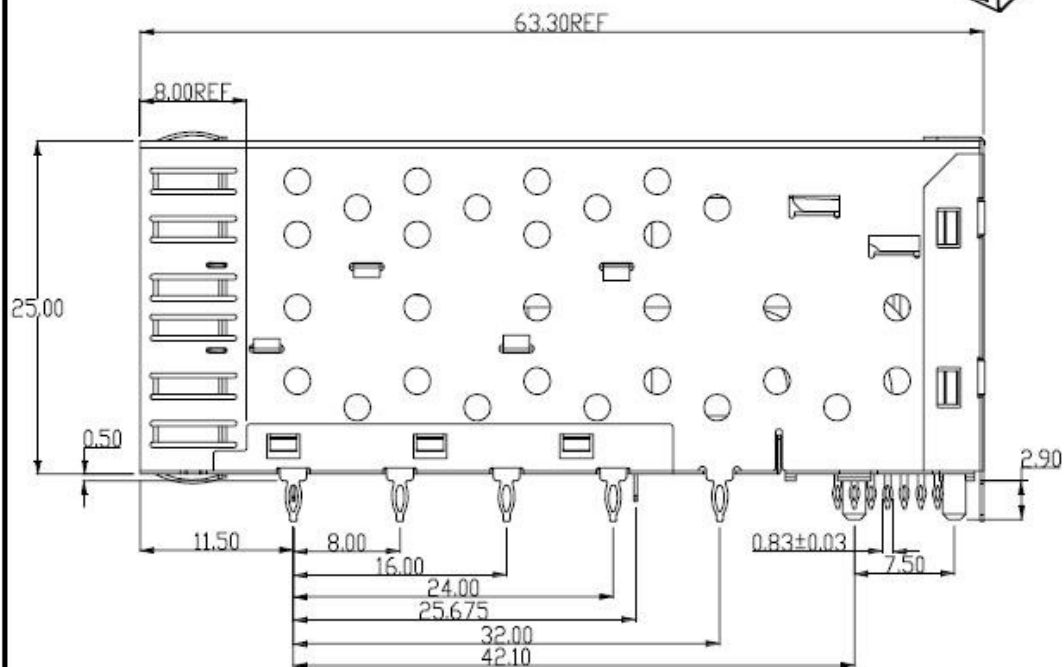

PRAN ELECTRONICS P. LTD.

TITLE SFP CAGE 2X1 PORT

DRAWING NO. SFP-021	SIZE	REV
PART NO. SEE NOTE		0
DO NOT SCALE DRAWING	SHEET 1	OF 1

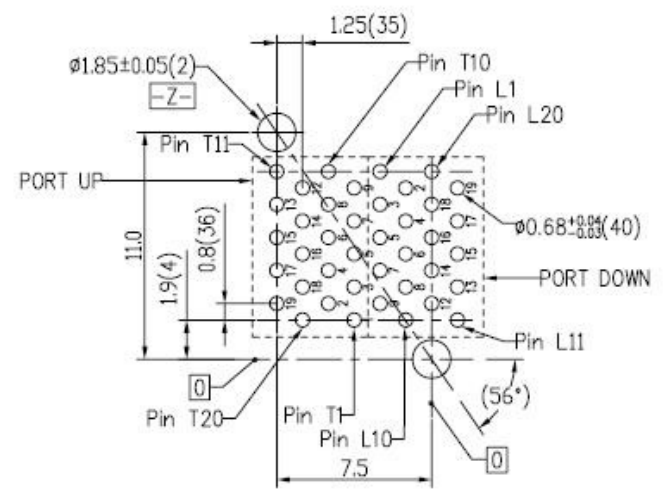
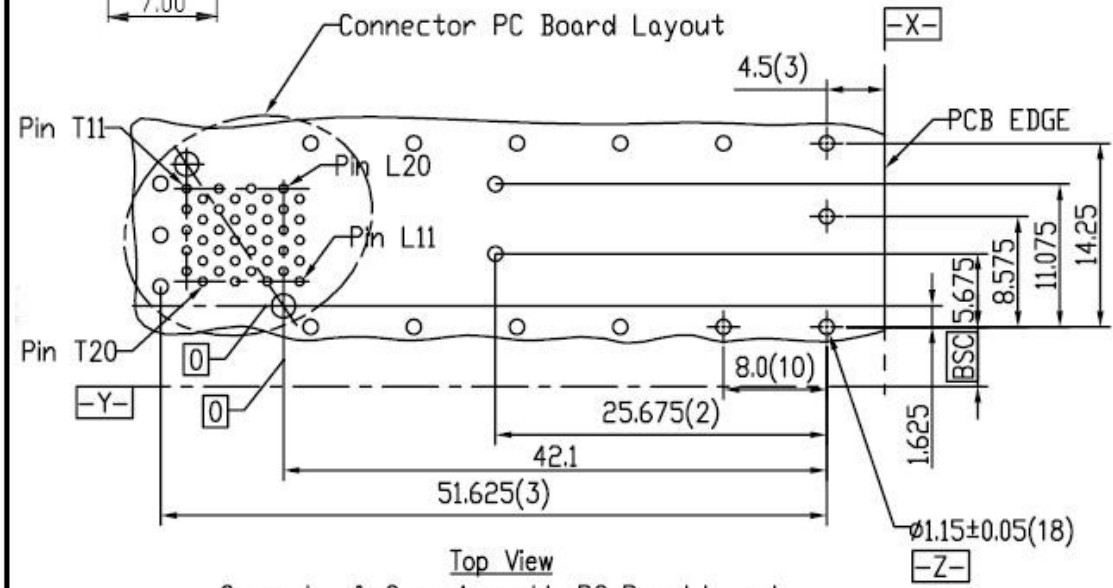
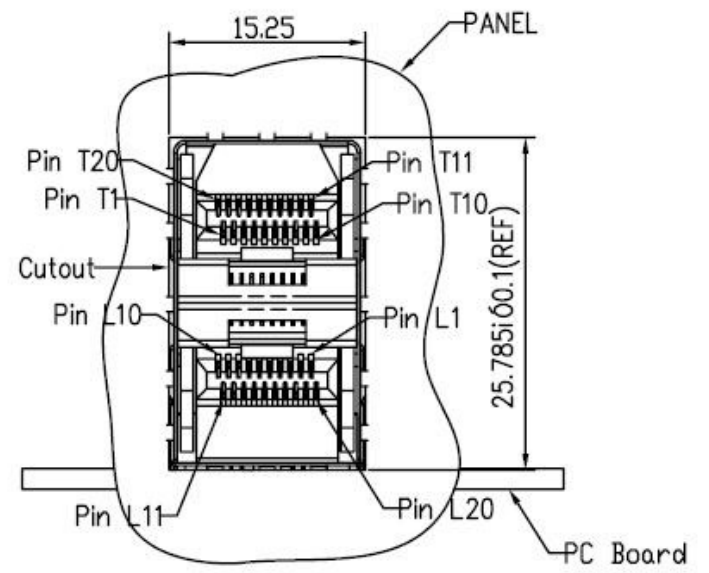
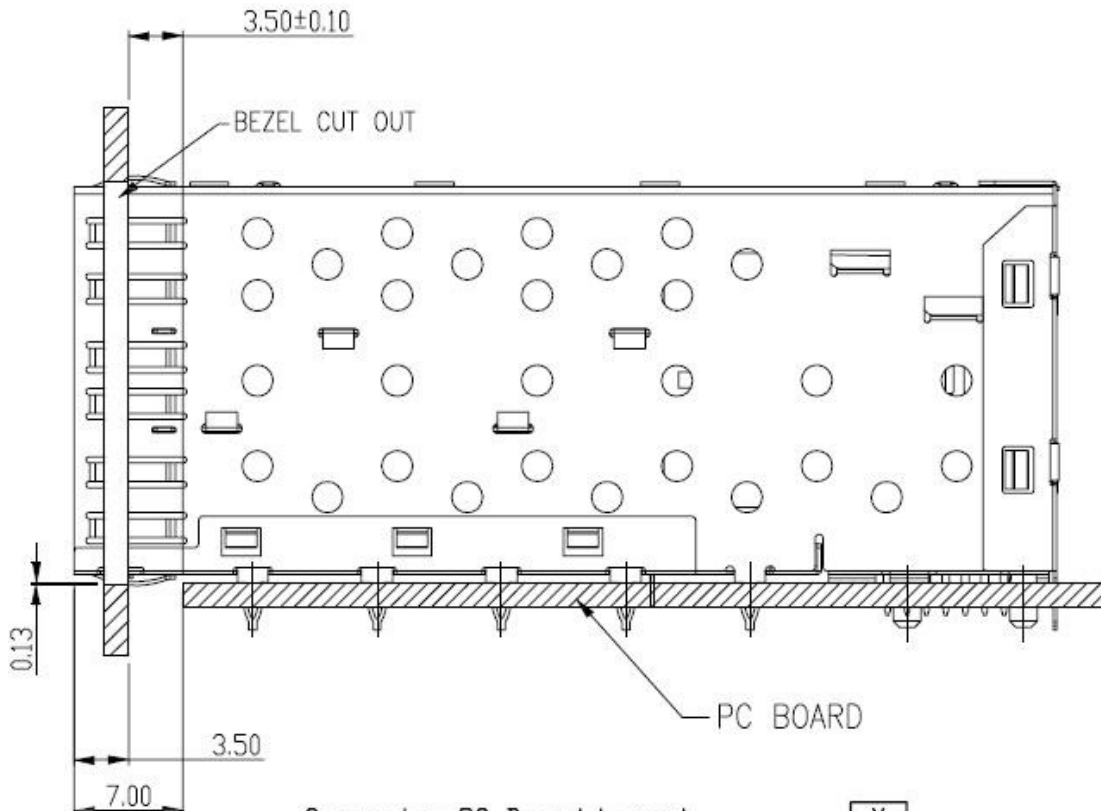

CONNECTOR PC Board Layout

Top View  
Connector & Cage Assembly PC Board Layout

PRAN ELECTRONICS P. LTD.			
TITLE SFP CAGE 2X1 PORT			
DRAWING NO. SFP-021	SIZE	REV	
PART NO. SEE NOTE		0	
DO NOT SCALE DRAWING	SHEET 1	OF 1	