

## 6x6mm 2 PIN RADIAL SWITCH

ROHS COMPLIANT

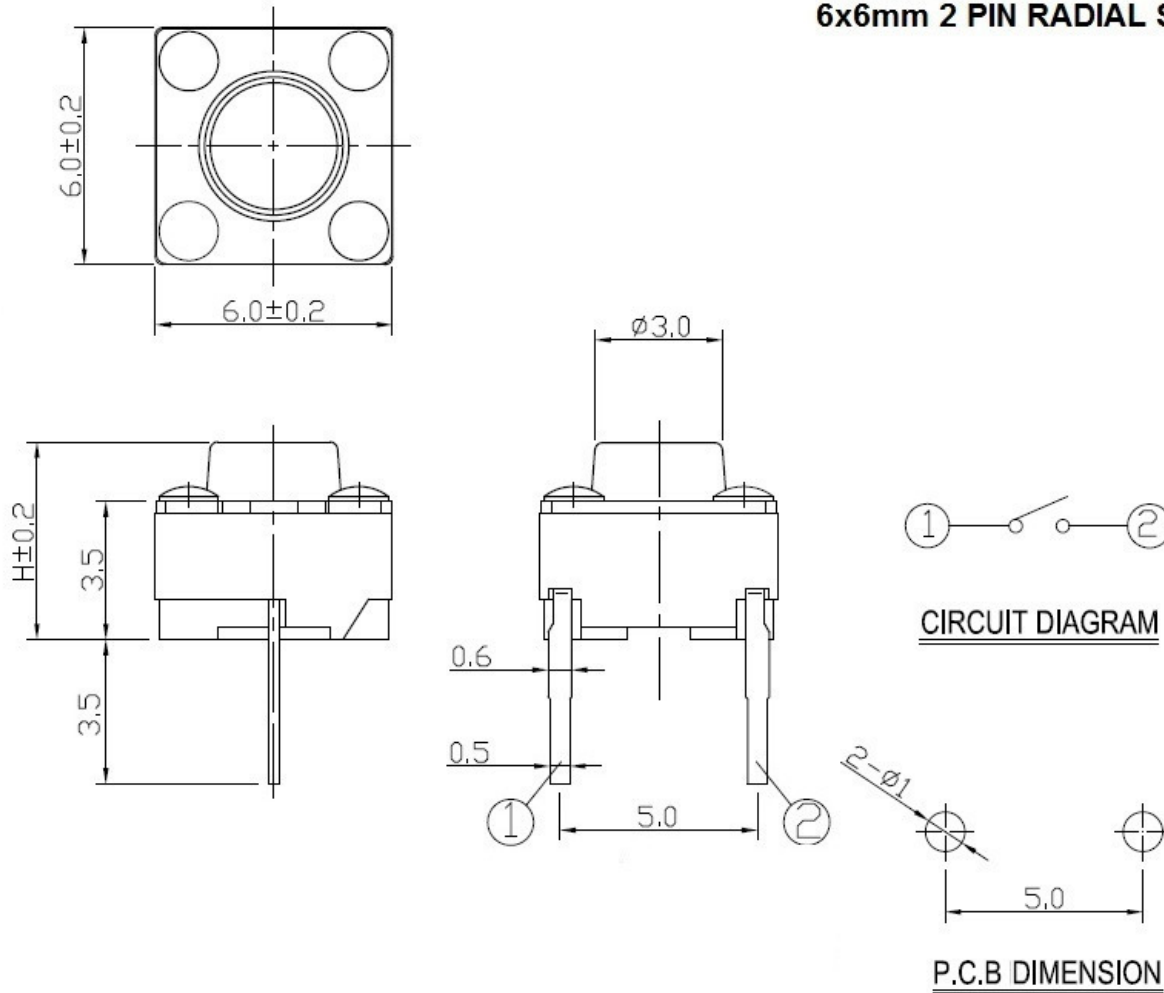

### SPECIFICATIONS:

Rating: 50mA x 12V DC

Contact resistance: 100 mOhms max.

Proof Voltage: 250V AC for 1 minute

Insulation Resistance: 100 MOhms minimum/100VDC

Operating Life: 100,000 cycles PhBz contact

Operating Force: 160 +/- 50gf

Push Plate colour: Black

Travel: 0.25 +/- 0.10mm

Operating Temperature: -40 to 85 Deg. C

Soldering Temperature: 270 +/- 10 Deg. for 3 sec.

Part Code	H = Height mm
60-2A2A	4.3
60-2A2B	5.0
60-2A2C	7.0
60-2A2D	8.0
60-2A2E	9.5
60-2A2F	12.5

### Raw Material:

S.NO.	PART	MATERIAL	QTY
1	BASE	PA66/NYLON6/6	1
2	TERMINAL	Brass Silver Plated	2
3	DOME CONTACT	Phosphor Bronze/Silver Clad	1
4	KNOB	PA 66	1
5	COVER	Plastic Film	1

DO NOT SCALE DRAWING  
DIMENSIONS IN MM  
GENERAL TOLERANCE +/-0.2MM

Rev. 2 date 28/9/2023



PRAN ELECTRONICS PVT. LTD.  
52, GIDC, MAKARPURA,  
VADODARA, 390010.  
INDIA